

2. DESIGN CRITERIA

2.20 Parking Criteria

In considering what level of parking provision is required Herefordshire Council has deemed it is most important to evaluate the accessibility of alternative modes of transport. The mainly rural nature of much of Herefordshire makes walking and cycling a viable alternative only in the larger villages, market towns and Hereford City. Access to public transport varies across the county with the highest levels of accessibility concentrated in Hereford and the Market Towns, which have a reasonable level of access to buses and rail access in Hereford, Ledbury and Leominster.

Herefordshire Council has deemed that parking standards need to allow for significantly lower levels of off street parking provision, particularly for developments:

- In locations, such as town centres, where services are readily accessible by walking, cycling or public transport;
- Which provide housing for elderly people, students and single people where the demand for car parking is likely to be less than for family housing; and
- Involving the conversion of housing or non residential buildings where off street parking is less likely to be successfully designed into the scheme.

Additionally, the Herefordshire Council has deemed that the Hereford Central Conservation Area, bounded in red on the

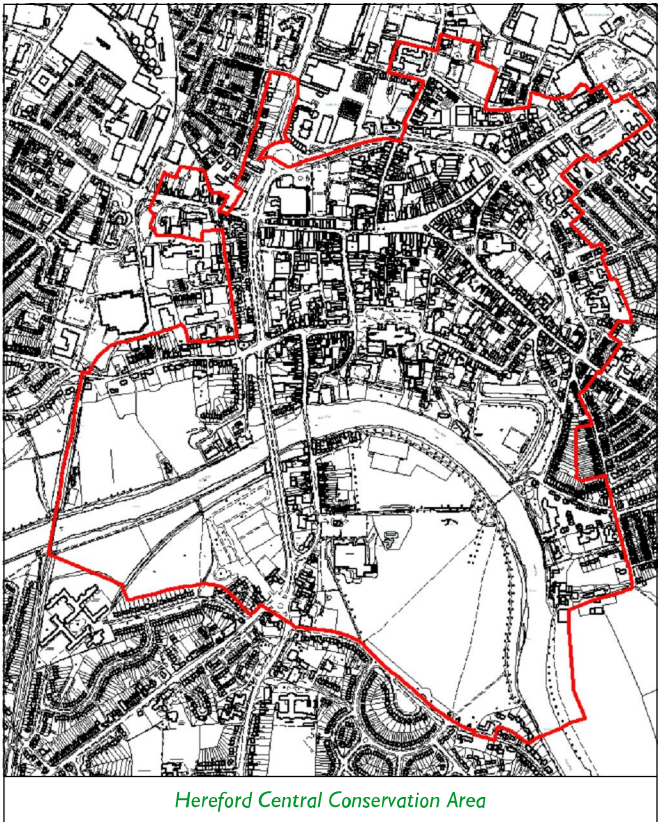

plan below and explained within the Unitary Development Policy, should be discouraged from developments that include additional car parking in order to encourage the use of alternative transport systems and modes of transport such as cycling. This will be further endorsed by encouraging the use of the strong transport links that Hereford enjoys with other major conurbations. Further guidance can be obtained from Planning Policy Guidance Note 3 (PPG 3).

Only certain sections of Hereford City have the necessary access to public transport and local facilities that allows the creation of a zone where all private non-residential parking will be discouraged. Developments in the centre of Hereford City should be discussed with the Transportation Section of the council, within this central zone residential parking will also be restricted but will be considered on the individual developments links with public transport and local facilities.



Residential parking requirements should be carefully considered

Herefordshire Council will support applications with reduced levels of parking in other areas providing there would be no detrimental impact on highway safety or local amenity. It is anticipated that these areas would be mainly within Hereford City and the Market Towns.

Where access to public transport or local facilities is poor increased residential parking spaces can be provided.

For developments at or above the PPG 13 Annex D thresholds the maximum parking standards would apply. However the Council would support applications with lower levels of parking providing there would be no detrimental impact on highway safety or local amenity.

**UDP Reference
H16 Car Parking
T11 Parking Provision**

Disabled Parking

For all types of non-residential development, except where specified otherwise in the following standards tables, the provision for disabled users parking should be 10% of all spaces with a minimum of 1 space per development.

This also applies to residential development with communal parking.

Consideration should also be made for powered motor vehicles (PMV's) for residential spaces; storage space should be provided within covered storage areas, with a dedicated power supply provided.

Notes on applying the Standards

The standards apply to new developments or extensions and to changes of use.

The standards apply to the external dimensioned floor area of buildings unless otherwise specified.

The design of parking areas and service areas should avoid the need for vehicles to reverse onto the highway and in the case of service vehicles, manoeuvre or wait on the highway.

Where parking spaces are orientated at an angle of less than 90° the aisle should indicate one-way flow through the car park or alternatively turning areas will be required to avoid excessive manoeuvring.

Mixed uses will be assessed as a sum of the parking requirement of the individual elements of the scheme based on the standards. However, if for example a building used for commercial purposes has facilities for a recreational function used only by the incumbent workforce, the standards necessary for the commercial use only need be applied.

Motorcycle Parking

The provision for motorcycle parking should be based on the modal split obtained from the 2001 Census. For Hereford this should be taken at 2%. Motorcycle parking should therefore



Motorcycle parking spaces are available

be provided at this level. Motorcycle parking should be designed in accordance with IHIE Guidelines For Motorcycling (April 2005).

www.ihie.org.uk

Dimensions and Location of Parking Spaces

The average car parking space measures 4.8m long and 2.4m wide with a 6m aisle when parking is at right angles. Alternative ways of arranging parking are shown on page 35.

The provision for disabled spaces is given in the parking standards and complies with the recommendations of BS 8300:2001; in grouped residential parking with less than 20 standard spaces there should be 1 space per group. Above this there should be one space for every 10 standard spaces. For disabled users car spaces should be 4.8m long and 3.6m wide but spaces of 2.4m width can be used where a shared space of 1.2m is demarked between the spaces.

For aesthetic reasons parking areas should be located behind the building line although sheltered on-street parking can be used as a speed restraint measure.

Communal visitors' spaces may be provided by widening the carriageway to accommodate a row of cars parallel to, at right angles to or at an angle to the kerb. Areas should be limited in size and numbers of spaces, and should form part of a landscaping and urban design proposal and again should serve the additional purpose of restraining vehicle speed. Groupings should be spread around the road to reduce visual impact. In the case of angled parking, the footway should be widened by 800mm to allow for vehicle overhangs.

Although residents' spaces and garages may be located on or near the frontage they should not dominate the street scene. Residents' spaces may also be located at the rear of dwellings and accessed from a separate road or drive. The parking should have natural surveillance as mentioned in Section 1.10 and the parking should be as convenient as possible to prevent resident on-street parking.

Garages

Garages should have internal dimensions to accommodate a cycle which can exit without removal of the car. Minimum internal dimensions of 4.8m x 2.4m are only acceptable where covered and secure cycle parking is provided elsewhere on the plot. Garage doors must not open over the adopted highway and visibility splays apply as for the parking spaces above.

Cycle Parking

The standards in the tables set out Herefordshire Council's minimum requirements in terms of cycle parking for new developments and changes in use. In addition to the application of these standards, new developments will have to comply with the following principles:

2. DESIGN CRITERIA

- Cycle racks or stands should conform to the design and dimensions as set out under Cycle Stand Design below;
- For residential purposes, cycle parking should be within a covered, lockable enclosure. For individual houses this could be in the form of a shed or garage. For flats or student accommodation either individual lockers or cycle stands within a lockable, covered enclosure are required;
- Cycle parking for employees should be, wherever practical, covered and in a convenient, secure location;
- Short stay cycle parking, e.g. for visitors or shoppers, should be located as near as possible to the main entrance of buildings and covered by natural surveillance or CCTV. For large developments the cycle parking facility should be covered;
- Reference to staff should be taken to mean the peak number of staff expected to be on site at any one time;
- All cycle parking should minimise conflicts between cycles and motor vehicles; and
- Some flexibility will be applied to applications where it can be demonstrated that strict adherence to the standards, e.g. for a multi-purpose site, is likely to result in a duplication of provision. Similar flexibility will apply for applications in the centre of Hereford or the Market Towns where land constraints may make application of the standards difficult for change of use or refurbishment.

Cycle Stand Design

A Sheffield Stand is preferred as it provides support and a suitable means of locking both wheels and frames for security. The Rounded A design provides additional support, particularly for smaller bicycles.



Sheffield Stand

These are simple, provide a convenient way to secure both a bike's frame and wheels, and accommodate different size bikes easily. If stands are spaced as recommended, they will accommodate two bikes per stand, offering a very economical solution.



Rounded A Stand

We do not recommend 'butterfly' type racks or variations such as wheel slots in the ground, as they do not offer proper security and will lead to damaged wheels if the bike is knocked over. It may be possible to attach robust rings or bars to walls to provide securing points for parking parallel to walls, where space is at a premium.

Cycle Parking Layout

This diagram shows the spacing required for cycle stands. There should be at least 1000mm gap between a double row of stands. All measurements shown are in millimetres.

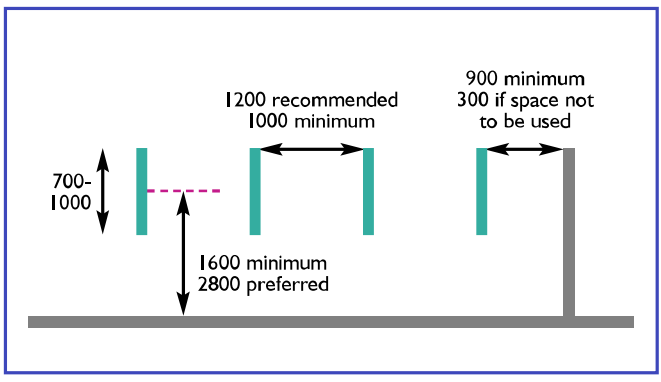

Arrangement at 90° to Wall

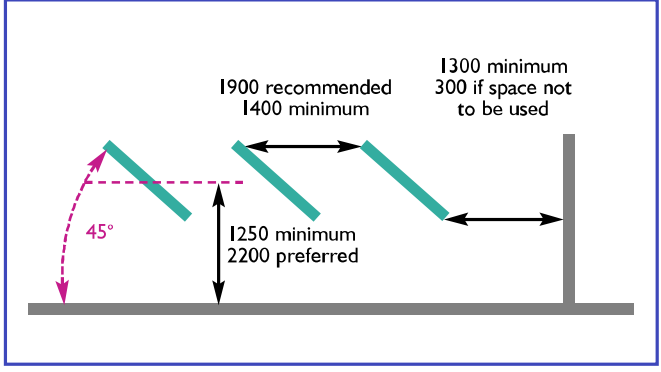

Arrangement at 45° to Wall

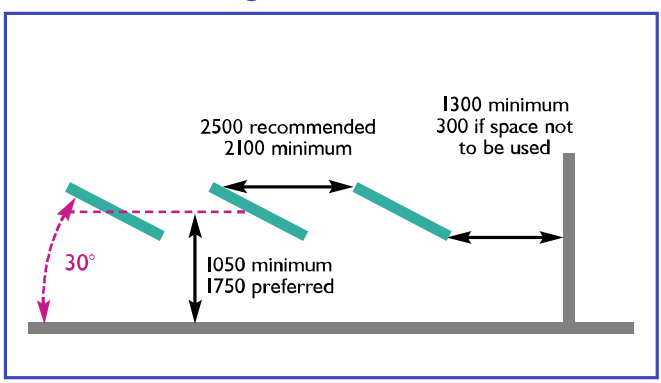

Arrangement at 30° to Wall

Cycle Parking Lockers

Longer-term parking might be usefully provided by cycle lockers, which provide convenient space for storing helmets and clothing, whilst also offering greater protection against vandalism or theft of accessories such as lights and saddles.

Rather than prescribe specific styles of parking stand or locker, it's more practical to specify a basic envelope of 0.9m x 2.0m, which can store 1 or 2 bikes and even tricycles. This envelope can be part of but not included in the garage allowance for a motor car or else provided as a further internal or external space, with an access route at least 0.8m wide 2.0m high - the store itself can be lower e.g. 1.4m.

Alternative Ways of Arranging 12 Car Parking Spaces

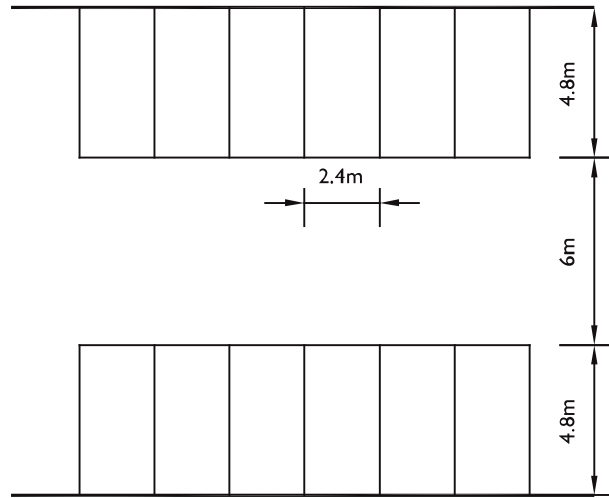

90° PARKING

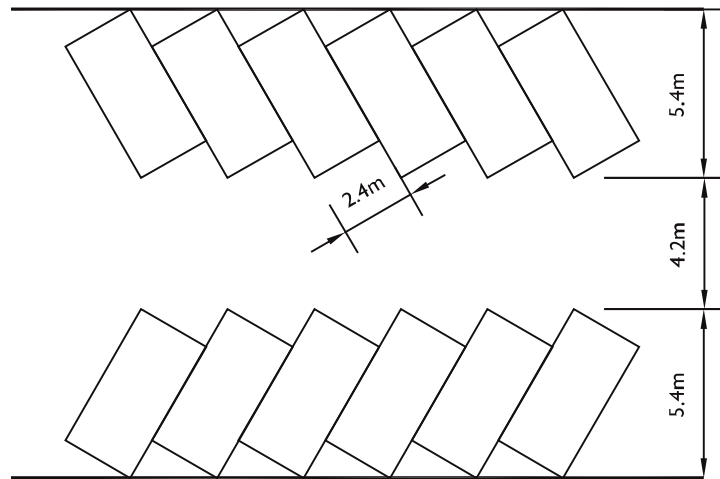

60° PARKING

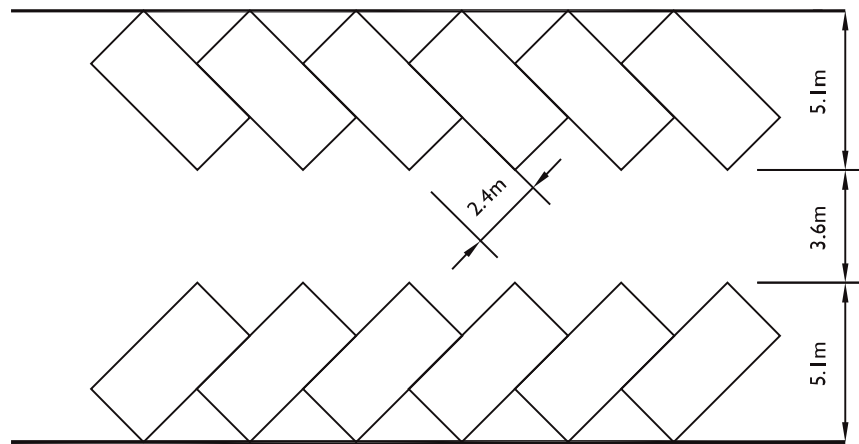

45° PARKING

2. DESIGN CRITERIA

Grouped Car Parking With direct access to highway up to maximum of 5 bays

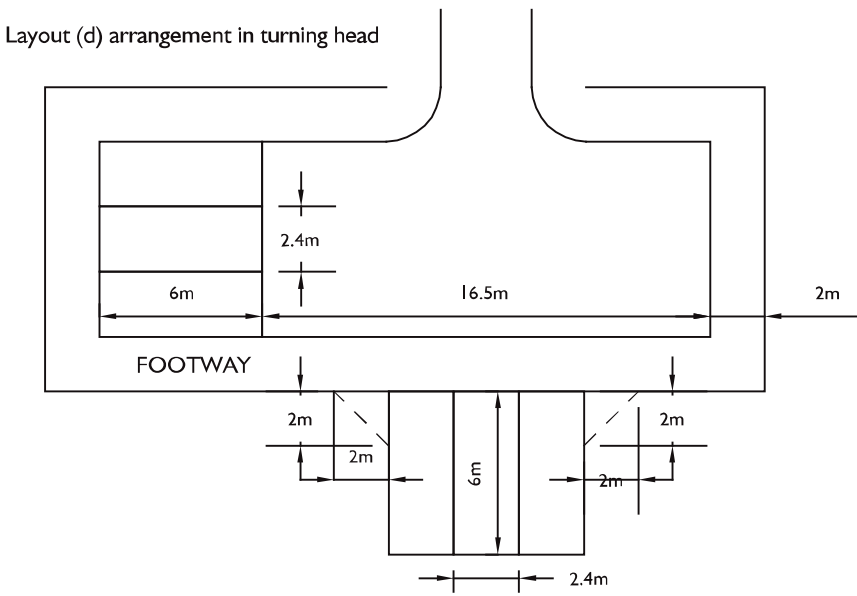
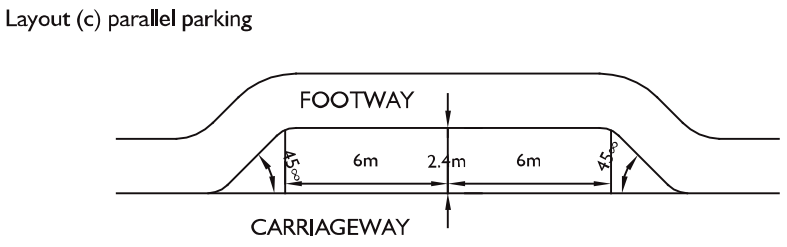
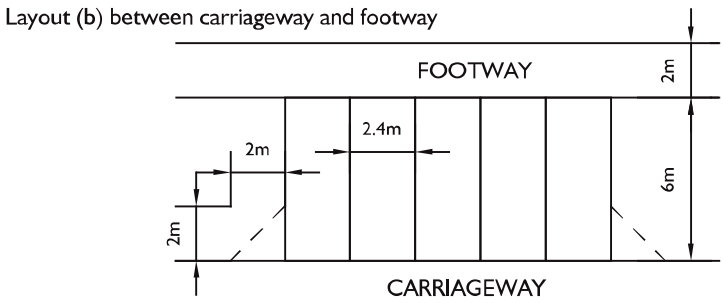
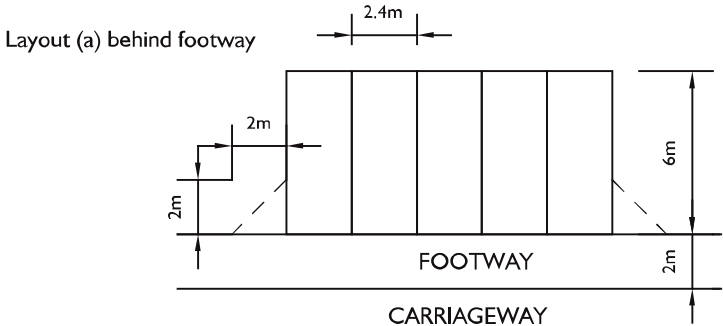

Parking for the Disabled

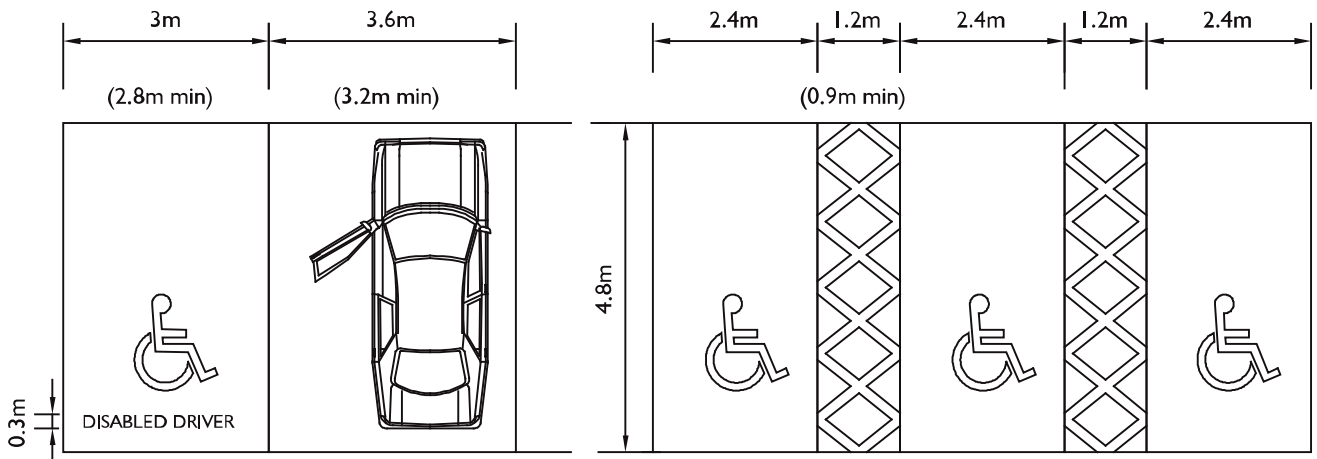

Ambulant disabled user - only where space is limited full width for wheelchair user preferred particularly in public car parks

Wheelchair user

Marked out shared space between 2 standard bays

Standard end bay with long side open for access

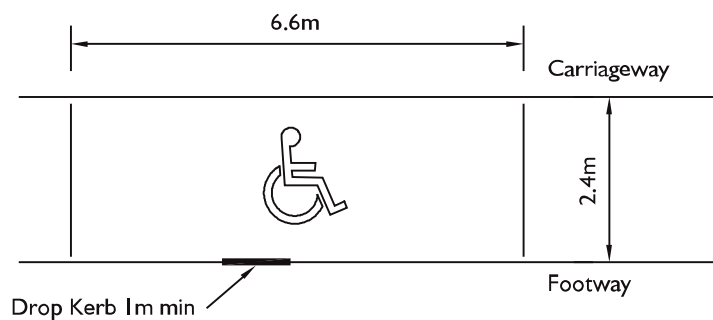

Parking side-on to kerb

2. DESIGN CRITERIA

Standards

The following standards shall apply throughout Herefordshire generally. They will apply generally for individual or smaller residential developments up to 25 units outside Hereford City's Central Conservation Area and thereafter the approach of PPG3 (2003) and PPG 13 (2001) will be applied i.e. standards are **maximums**.

In respect of non-residential use the following standards apply throughout Herefordshire generally. As with all standards they are maximum provision. They are based upon PPG 13 and the minimum application thresholds are stated.

Class	CAR PARKING STANDARDS			CYCLE PARKING STANDARDS	
	Description	Standard	Operational Space	Long Stay	Short Stay
A1 Shops and Retail Outlets	Shops under 2000sq.m of gross floor area	1 car space/25 sq.m of gross floor area	1 lorry space/750 sq.m of gross floor area. Minimum of 1 space/unit unless grouped servicing arrangements when there shall be a minimum of 3 spaces/3 units where total floor space of 3 units does not exceed 1500 sq.m	Greater of 1 space per six staff or 1 space per 300 sq.m GFA	1 space per 100 sq.m GFA
	Supermarket, cash and carry, super stores and hypermarkets	Generally 1 space for each disabled employee (if numbers are known) and spaces at the rate of 1 for every 20 other spaces		Greater of 1 space per six staff or 1 space per 300 sq.m. GFA	Greater of 15% of car spaces or 1 space per 100 sq.m GFA
	a) Over 2000 sq.m gross floor area in established shopping centres or retail parks	1 car space/25 sq.m of gross floor area	1 lorry space/750 sq.m of gross floor area. Minimum of 3 lorry spaces. Service area to be segregated from service area of other shops		
	*b) Over 2000 sq.m gross floor area, stand-alone out of centre food stores	1 car space/ 20 sq.m of gross floor area	1 lorry space/750 sq.m of gross floor area. Minimum of 3 lorry spaces		
	*c) Over 2000 sq.m gross floor area, stand-alone out of centre non food stores	1 car space/20 sq.m of gross floor area	1 lorry space/750 sq.m of gross floor area. Minimum of 3 lorry spaces		

* Out of town may include development immediately adjacent to Town Centre but not within central core

Class	CAR PARKING STANDARDS			CYCLE PARKING STANDARDS	
	Description	Standard	Operational Space	Long Stay	Short Stay
A1 Shops and Retail Outlets continued	Garages and motor car showrooms	Add together the number of spaces required for each category. Appropriate parking to be allowed for retail use (A1).			
	Repair Garages	<p>1 Space for each disabled employee (if disabled numbers are known) and 1 space for disabled users for every 15 other spaces</p> <p>Spare part store: 1 car space/25sq.m of gross floor area if a main distributor</p> <p>Workshop: 4 car spaces/bay or 2 lorry spaces plus 1 car space if a lorry repairs shop.</p> <p>MOT bays: minimum 4 car spaces/bay</p>	<p>1 lorry space unless provided under another category</p> <p>Ancillary vehicles: Minimum 3 lorry spaces</p>		
	Car sales area	<p>Offices: 1 car space/25 sq.m of gross floor area</p> <p>1 space for each disabled employee (if numbers are known) and 1 disabled space for every 10 other spaces</p> <p>Sales - main distributor: 1 car space/50 sq.m of sales area.</p> <p>Other: 1 car space/100 sq.m of sales area. Minimum of 2 spaces</p>	Space for car transporter		
	Petrol filling station	2 car spaces/pump plus minimum of 1 lorry space overall	Space for petrol tanker		
	Car wash	5 spaces for waiting	1 lorry space unless provided another category		
	Tyre and exhaust centre	4 car spaces/repair bay 2 lorry spaces/lorry repair bay			

2. DESIGN CRITERIA

Class	CAR PARKING STANDARDS			CYCLE PARKING STANDARDS	
	Description	Standard	Operational Space	Long Stay	Short Stay
A2 Financial and Professional Services (Threshold 1000 sq.m)	Betting offices Banks Building Societies Other Services	1 Space for each disabled employee and 1 disabled space for every 50 other spaces 1 car space/30sq.m of gross floor area	1 lorry space/1000 sq.m of gross floor area. Minimum 1 space/unit unless grouped servicing arrangements when there shall be a minimum of 2 spaces/3 units where total floor space of 3 units doesn't not exceed 2000 sq.m	Greater of 1 space per six staff or 1 space per 300 sq.m. GFA	Greater of 15% of car spaces or 1 space per 200 sq.m. GFA
A3 Restaurants and Cafes (Threshold 1000 sq.m)	Restaurants and Cafes	1 car space/5sq.m of gross floor area. Plus appropriate standard for dwelling accommodation	1 lorry space/1000 sq.m of gross floor area. Minimum 1 space/unit unless grouped servicing arrangements when there shall be a minimum of 2 spaces/3 units where total floor spaces of 3 units does not exceed 2000 sq.m	Greater of 1 space per six staff or 1 space per 50 sq.m GFA	1 space per 10 sq.m Dining area
	Transport cafe	1 lorry space/5sq.m of gross floor area	1 lorry space minimum		
A4 Drinking Establishments (Threshold 1000 sq.m)	Pubs and Clubs	1 car space/5sq.m of gross floor area. Plus appropriate standard for dwelling accommodation (C3)	1 lorry space/1000 sq.m of gross floor area. Minimum 1 space/unit unless grouped servicing arrangements when there shall be a minimum of 2 spaces/3 units where total floor spaces of 3 units does not exceed 2000 sq.m	Greater of 1 space per six staff or 1 space per 50 sq.m GFA	1 space per 10 sq.m dining area

Class	CAR PARKING STANDARDS			CYCLE PARKING STANDARDS	
	Description	Standard	Operational Space	Long Stay	Short Stay
A5 Takeaways (Threshold 1000 sq.m)	Takeaway's	1 car space/ 5sq.m of gross floor area	1 lorry space where gross floor area exceeds 750 sq.m	Greater of 1 space per six staff or 1 space per 50 sq. m. GFA	1 space per 50 sq. m. GFA
	Roadside restaurant	1 car space/ 5sq.m of gross floor area	1 lorry space minimum		
		<p>For all above cases, (Class A3, A4 and A5) 1 space for each disabled employee (if numbers are known) and 1 disabled space for every 10 other spaces.</p> <p>If only open in the evenings, consideration will be given to dual use of spaces in public car parks.</p>			

2. DESIGN CRITERIA

Class	CAR PARKING STANDARDS			CYCLE PARKING STANDARDS	
	Description	Standard	Operational Space	Long Stay	Short Stay
B1 Business (Threshold 1000 sq.m)	Office, research and Development	1 car space/25 sq.m of gross floor area	1 lorry space/ 250sq.m of gross floor area. Minimum of 1 space	Greater of 1 space per six staff or 1 space per 150 sq.m GFA	1 space per 500sq.m of GFA
	Light Industry, 'Hi Tech' Park			Greater of 1 space per six staff or 1 space per 250 sq.m GFA	On merit
B2 General Industry (Threshold 1000 sq.m)		1 car space/25 sq.m of gross floor area up to 250 sq.m per individual unit. Over 250 sq.m 1 additional car space/50 sq.m of gross floor area	1 lorry space/250 sq.m of gross floor area. Minimum 1 space	Greater of 1 space per six staff or 1 space per 500 sq.m GFA	On merit
B8 Storage and Distribution (Threshold 1000 sq.m)	Warehouse	1 lorry space minimum 1 space for each disabled employee (if numbers are known) or disabled space for every other 10 spaces.		Greater of 1 space per six staff or 1 space per 500 sq.m GFA	On merit
	Transport Depot	To be assessed on individual merit			

Class	CAR PARKING STANDARDS			CYCLE PARKING STANDARDS	
	Description	Standard	Operational Space	Long Stay	Short Stay
C1 Hotels, Motels (Threshold 2500 sq.m)	Hotels and Motels (more than 20 bed spaces)	1 car space/ bedroom plus non-residential staff parking at 1 car space/25 sq.m of all other floor area	Minimum 1 lorry space and manoeuvring space for a coach	Greater of 5 space per six staff or 1 space per 50 sq.m GFA	2 spaces minimum, 1 space per five bedrooms
		Appropriate parking to be allowed for restaurant, bar, function rooms etc. (A3) open to non-residents and appropriate standard for dwelling accommodation (C3) 1 space for each disabled employee (if numbers are known) or 1 disabled space for every other 20 spaces.			
	Guest houses (less than 20 bed spaces)	1 car space/ bedroom			
		Appropriate standards for dwelling accommodation (C3) and restaurant facility open to non-residents (A3)			
C2 Residential Institutions (Threshold 1000 sq.m)	Hospitals	1 car space per bed plus residential accommodation at 1 car space/self-contained flat. Clinic and outpatients parking as for doctors surgeries (D1)	Operational space depends on type and needs of hospital	1 space per six staff	On merit as per travel plan
	Nursing home/sheltered accommodation for the inactive elderly/handicapped and mentally ill	1 car space/4 beds. Warden provision as for C3	Minimum of 1 lorry/ambulance space	1 space per six staff	One space per 10 residents
		Defined as a scheme specifically designed for the elderly with a common room or rooms with a minimum floor area of 1.8 sq.m per bed space, all accommodation to be accessible by enclosed and heated circulation area 1 space for each disabled employee (if numbers are known) or 1 disabled space for every other 20 spaces			
Residential school/training	1 car space/bed. Separate staff accommodation as for C3	Minimum 1 lorry space	1 space per six staff	One space per 5 residents	

2. DESIGN CRITERIA

Class	CAR PARKING STANDARDS			CYCLE PARKING STANDARDS	
	Description	Standard	Operational Space	Long Stay	Short Stay
C3 Dwellings for areas outside Hereford City central area	Units with 1 bedroom where grouped parking	Max 1 car spaces/unit		One locker per unit (see design notes)	One space per unit
	Units with 1 bedroom where individual parking	Max 1 car spaces/unit *		One locker per unit (may be provided by a garage)	One space per unit
	Units with 2 or 3 bedrooms where grouped or individual parking	Max 2 car spaces/unit *		One space per bedroom (may be provided by a locker or garage)	One space per unit
	Units with more than 3 bedrooms where grouped or individual parking	Max 3 car spaces/unit *		One space per bedroom (may be provided by a locker or garage)	One space per unit
	This should produce an average maximum rate of 1.5 spaces per unit for the development.				
	Sheltered accommodation for the elderly:				
	a) Retirement units for Active elderly or aged person's dwellings with no communal and living facilities.	Normal dwelling standards apply		Normal dwelling standards apply	Normal dwelling standards apply
	b) Sheltered accommodation with a common room and resident Warden	0.5 car spaces/unit. Warden accommodation as for dwellings	Minimum of 1 lorry/ambulance space	Warden accommodation as for dwellings	One space per 5 units
Mobile homes and residential caravans	1.5 car spaces/units				
Transit or static holiday caravan sites	1 car space/caravan	1 car spaces/8 caravans			

* Note: The possible effect of garage being used for purposes other than parking a car should be considered.

Class	CAR PARKING STANDARDS			CYCLE PARKING STANDARDS	
	Description	Standard	Operational Space	Long Stay	Short Stay
DI Non-Residential Institutions	Doctors' surgeries, day clinics, dentists and health centres	4 car spaces per consulting or treatment room	1 ambulance spaces/4 consulting or treatment rooms	1 space per six staff	Two spaces per consulting room
	Crèche, day nursery and day centre	1 car space/member of staff or 1/15sq.m of gross floor area whichever is the greater		1 space per six staff	Minimum four spaces
	Schools	1 car space/15sq.m based on 1/8 pupils	1 coach space/ manoeuvring space per 100 pupils with provision for setting down and picking up. Space can be provided by using reinforced playgrounds and driveways	1 space per six staff in all schools, plus: Primary Schools: one space for 100% of year 6 pupils Secondary Schools: One space for 40% of all pupils	On merit as per travel plan
	Places of further education	1 car space/15 students where known or 1/10 sq.m of gross floor area whichever is the greatest 1 space/2 staff	1 lorry space/1000sq.m of gross floor area. Minimum of 1 space.	1 space per six staff and One space for 20% of all pupils	On merit as per travel plan
	Art gallery, museum, libraries	1 car space/30 sq.m of gross floor area	1 lorry space	1 space per six staff	1 space per 50 sq.m of GFA
	Public Hall, exhibition centre, place of worship	1 car space/10 sq.m of gross floor area	1 lorry space. Manoeuvring space for a coach where gross floor area exceeds 750 sq.m	1 space per six staff	1 space per 100 sq.m of GFA

2. DESIGN CRITERIA

Class	CAR PARKING STANDARDS			CYCLE PARKING STANDARDS	
	Description	Standard	Operational Space	Long Stay	Short Stay
D2 Assembly and Leisure (Threshold 2500 sq.m)	Theatre, cinema, concert Hall, bingo hall, dance hall Nightclub	1 car space/10sq.m of floor area. If only open in the evening consideration will be given to dual use of spaces in public car parks	1 ambulance spaces/4 consulting or treatment rooms	1 space per six staff	1 space per 200 sq.m of GFA
		Appropriate parking to be allowed for restaurant, bar Facilities etc. open to the general public (A3).			
	Public open spaces	4 car spaces/hectare	Minimum of 1 coach space/manoeuvring area	1 space per six staff	1 space/hectare
	*Sports facilities:				
	swimming pool	1 car space/5 sq.m of pool area	1 coach space/manoeuvring area	1 space per six staff	Greater of 1 space per 25 sq.m or 1 space per 10 sq.m pool area
	team games area	1 car space/2 team members	1 coach space per team/manoeuvring area	1 space per six staff	2 spaces per hectare
	golf course	60 car spaces/18 holes. 2 car spaces/bay if a golf driving range	1 coach space/manoeuvring area	1 space per six staff	On merit as per travel plan
leisure centre/sports centre/gymnasium	1 car space/10 sq.m of gross floor area Appropriate parking to be allowed for restaurant, bar facilities etc. open to the general public (A3)	1 coach space/manoeuvring area	1 space per six staff	1 space per 25 sq.m	
marina	1 car space/berth	Minimum 1 lorry space	1 space per six staff	On merit as per travel plan	
fishing lake	1 car space/peg		1 space per six staff	On merit as per travel plan	
Other	Allotments	10 car spaces/hectare		2 spaces per hectare	
	Kennels and Catteries	1 car space/4 pens		1 space per six staff	One space per 20 residents